

WATERCO®

Water, the liquid of life

MULTICYCLONE MC16 PLUS



The MultiCyclone Plus combines centrifugal and cartridge filtration into one streamlined housing, creating an ultra compact filtration system.

Features:

- Dual stage filtration
- Minimal maintenance
- Save water and energy
- Pleated filter cartridge

MULTICYCLONE MC16 PLUS

Dual Stage Filtration

Incoming water tangentially enters its multiple hydrocyclones, generating a strong centrifugal effect. Approximately 80% of the incoming dirt load is spiralled down to its clear sediment chamber. The outgoing water is finally polished via its inbuilt cartridge filter, producing crystal clear water.

Extended Filter Capacity

The MultiCyclone Plus's centrifugal section pre-filters up to 80% of the incoming dirt load before it reaches the filter cartridge, magnifying the capacity of its filter cartridge by up to 5 times. The MultiCyclone Plus has a filtration capacity equivalent to a 200 ft² cartridge filter or a 24" (600mm) sand filter.

Ultra Compact Filtration

The MultiCyclone Plus's streamlined design means the entire filtration system can be installed vertically, reducing the footprint of the equipment pad. Additionally, minimal pipework reduces the filtration system's overall head loss. Alternatively the MultiCyclone Plus can be installed next to the pump by using the optional base.

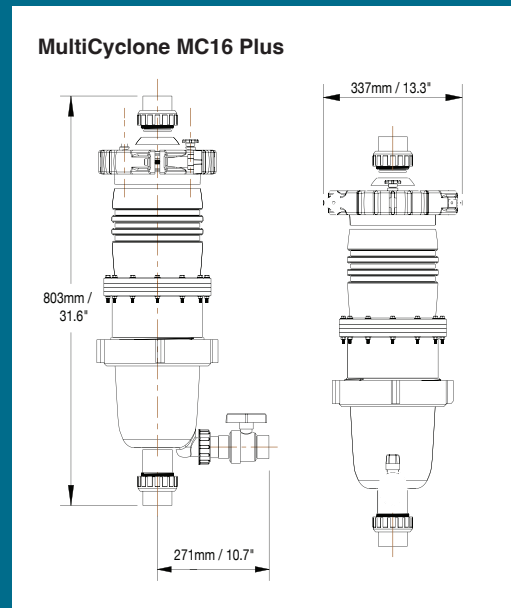

Technical Information

Model	Connection Ports	Minimum Flow Rate	Maximum Flow Rate	Filter Area	Maximum Pool Size	Maximum Pressure	Weight (kg)
MultiCyclone MC16 Plus	2" / 63 mm	3 m ³ /h	13.5 m ³ /h	40 ft ² / 3.7 m ²	80,000ft ³ / 80m ³	350kPa (50psi) 3.5 bar	12.5



The UK's Leading Independent Swimming Pool Manufacturer and Distributor